

6 Foot Guardian Park Bench

For Fastener Pack
(FP-GB6B-CU-00)

CUSTOMER NOTICE:

FOLLOW ASSEMBLY INSTRUCTIONS CLOSELY. DAMAGES DUE TO IMPROPER
ASSEMBLY WILL NOT BE COVERED UNDER WARRANTY.

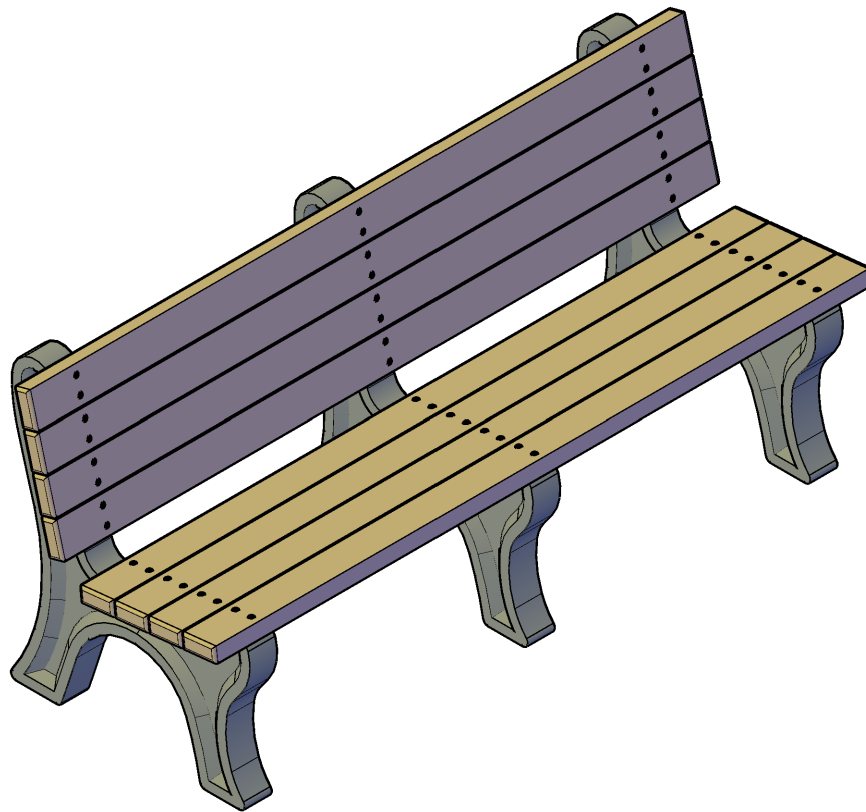

Congratulations !!

**You have just purchased the finest recycled plastic
park bench available. Enjoy !!!**

Before assembly, please make sure all components are included.



(1) - One Fastener Pack
FP-GB6B-CU-00

FP - Fastener Pack

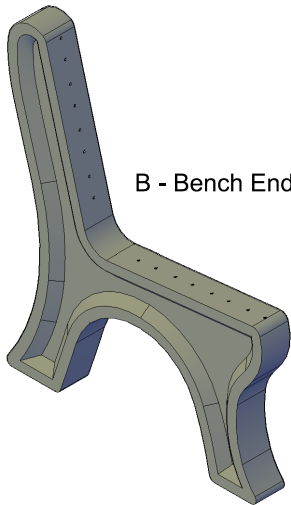

B - Bench End

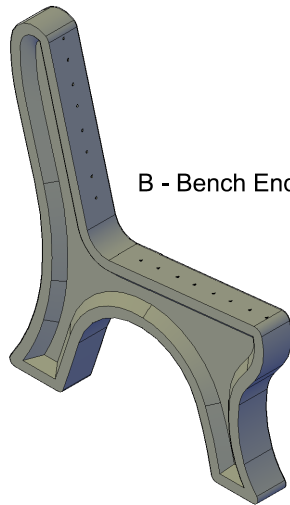

B - Bench End

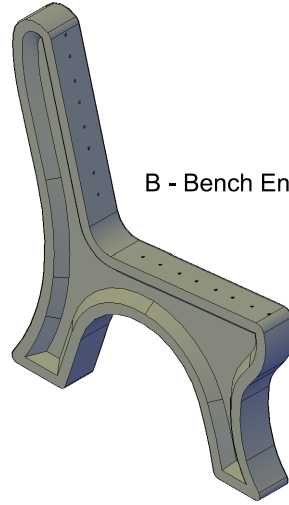

B - Bench End

(3) - Three Bench Ends
PS-SBBE-G-00

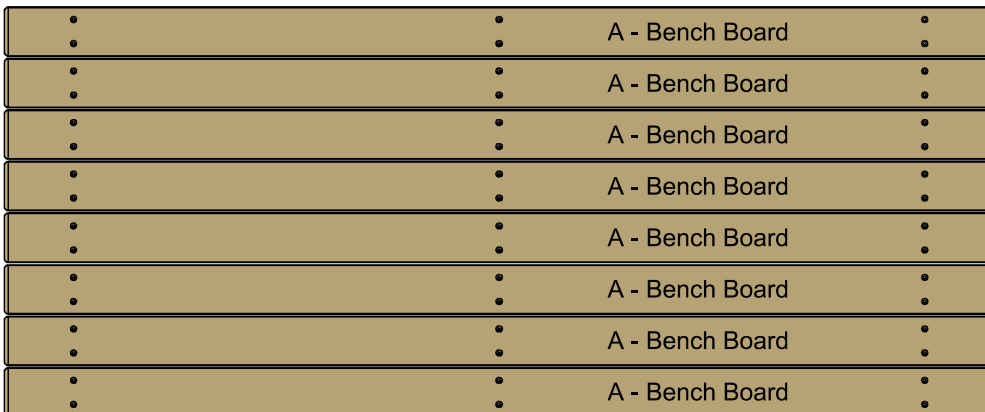

(8) - Eight Bench Boards
BP-DB6B-A-03

REFERENCE NOTE:

THE BACKSIDE OF EACH BOARD SHOULD BE MARKED WITH AN "X" ON ONE END. INSTALL BOARDS SO ALL "X's" ARE ON THE SAME END OF THE BENCH.

Before assembly, please make sure all fasteners are included.

48 - #12 x 3" Flat Head Phillips Screw



Also needed for this assembly will be the following materials:

1 - #3 Phillips Drive Bit

***IMPORTANT NOTICE*:**

- * **DO NOT OVER-TIGHTEN SCREWS.**
- * **USE A DRILL WITH ADJUSTABLE TORQUE FOR BEST RESULTS.**
- * **OVER-TIGHTENING WILL RESULT IN STRIPPING OUT THE PILOT HOLE, AND SCREW WILL "SINK" INTO THE PLASTIC WHICH MAY CAUSE A STRESS FRACTURE.**

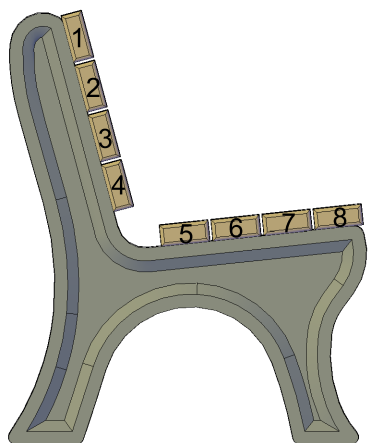
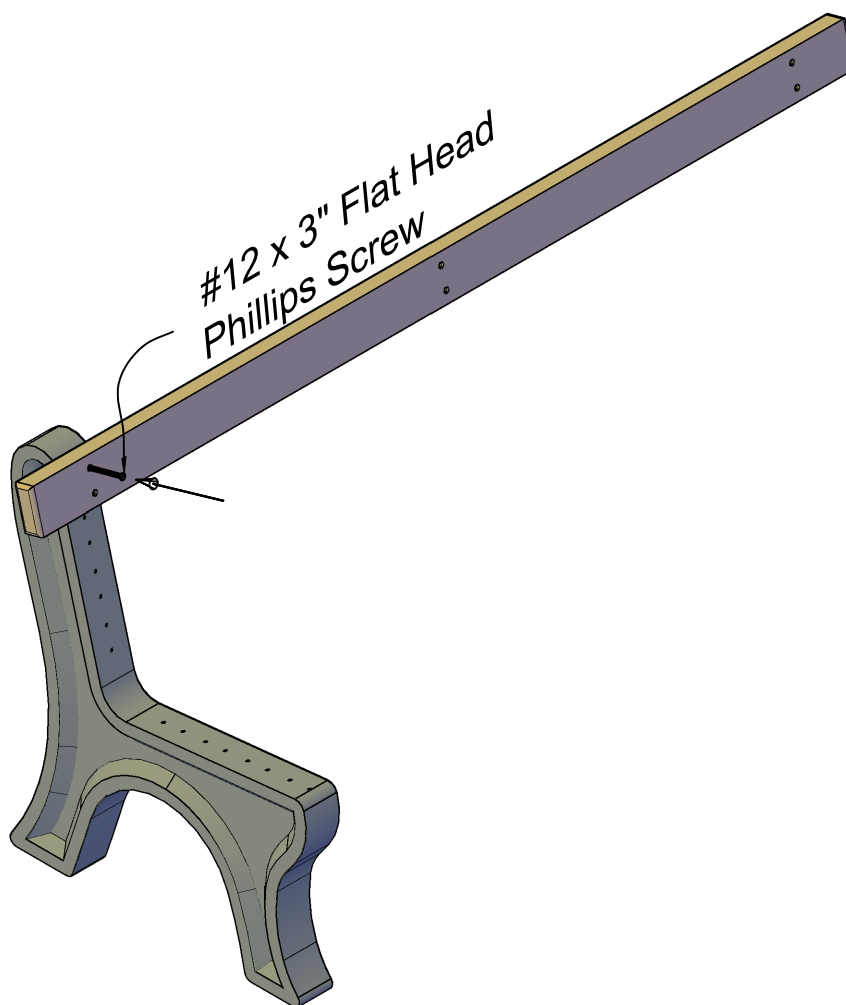

Fig #1:

In order to make the assembly of this Guardian Bench easier while going through the assembly process the board positions are numbered and will be referenced in later steps.

REFERENCE NOTE:
INSTALL BOARDS SO
ALL "X's" ARE ON THE
SAME END OF THE
BENCH.



Step #1:

Stand (1) One bench end upright and place (1) One bench board on position **1** being sure to align the pre-drilled holes to the pilot holes in the bench end. After the holes are properly aligned, fasten with (1) One #12 x 3" Flat Head Phillips Screw in the top pre-drilled hole.

Note: Do not tighten screw completely. This will be done in a later step.

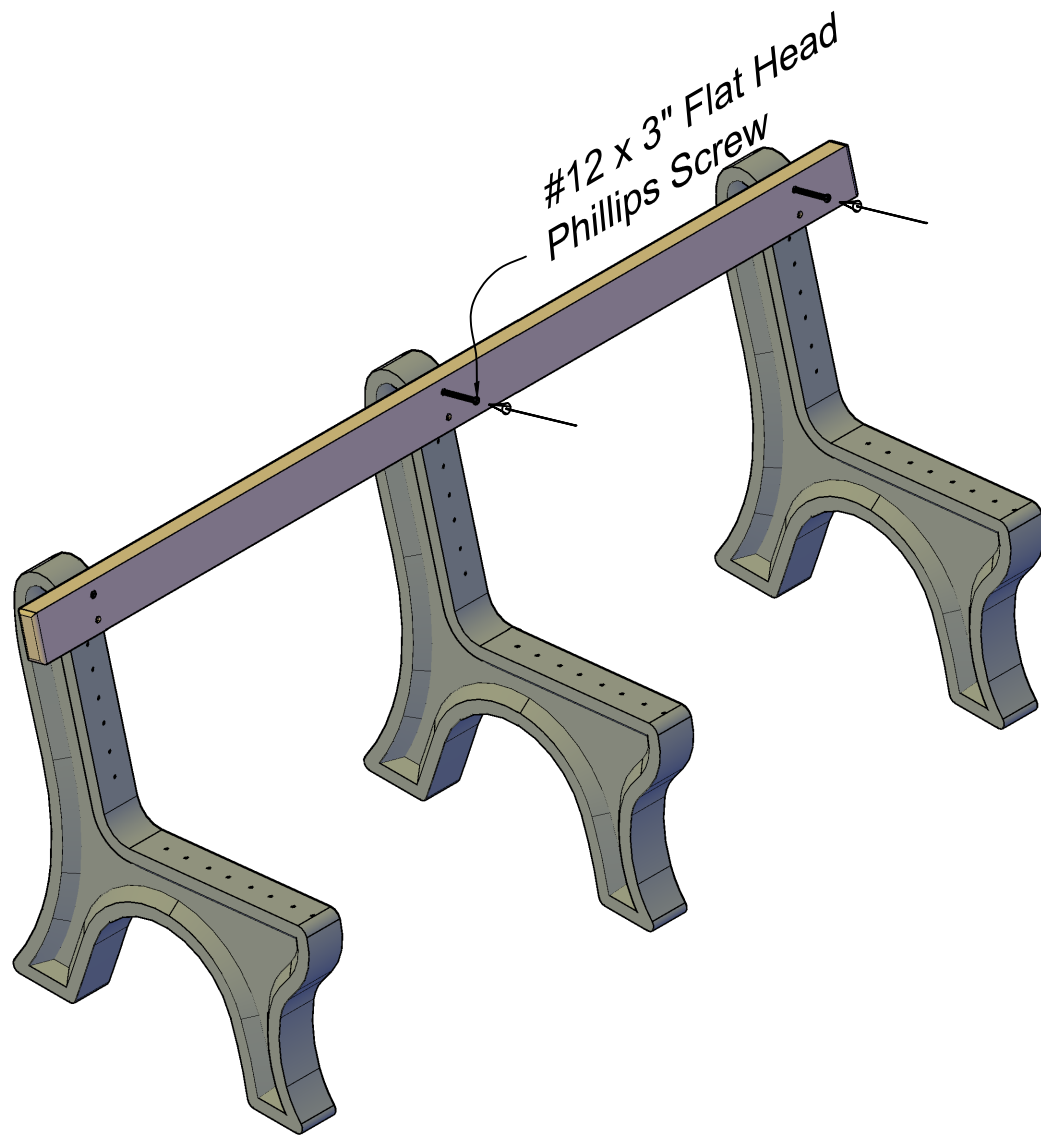

Step #2:

Stand the other bench end upright and place the bench board already attached to the first bench end, on position 1 being sure to align the pre-drilled holes to the pilot holes in the bench end. After the holes are properly aligned, fasten with (1) One #12 x 3" Flat Head Phillips Screw in the top pre-drilled hole.

Note: Do not tighten screws completely. This will be done in a later step.

Step #3:

Align bottom pre-drilled holes to the pilot holes in the bench end. After the holes are properly aligned, fasten with (1) One #12 x 3" Flat Head Phillips Screw per hole.

Note: Be sure to tighten screws completely after this step.

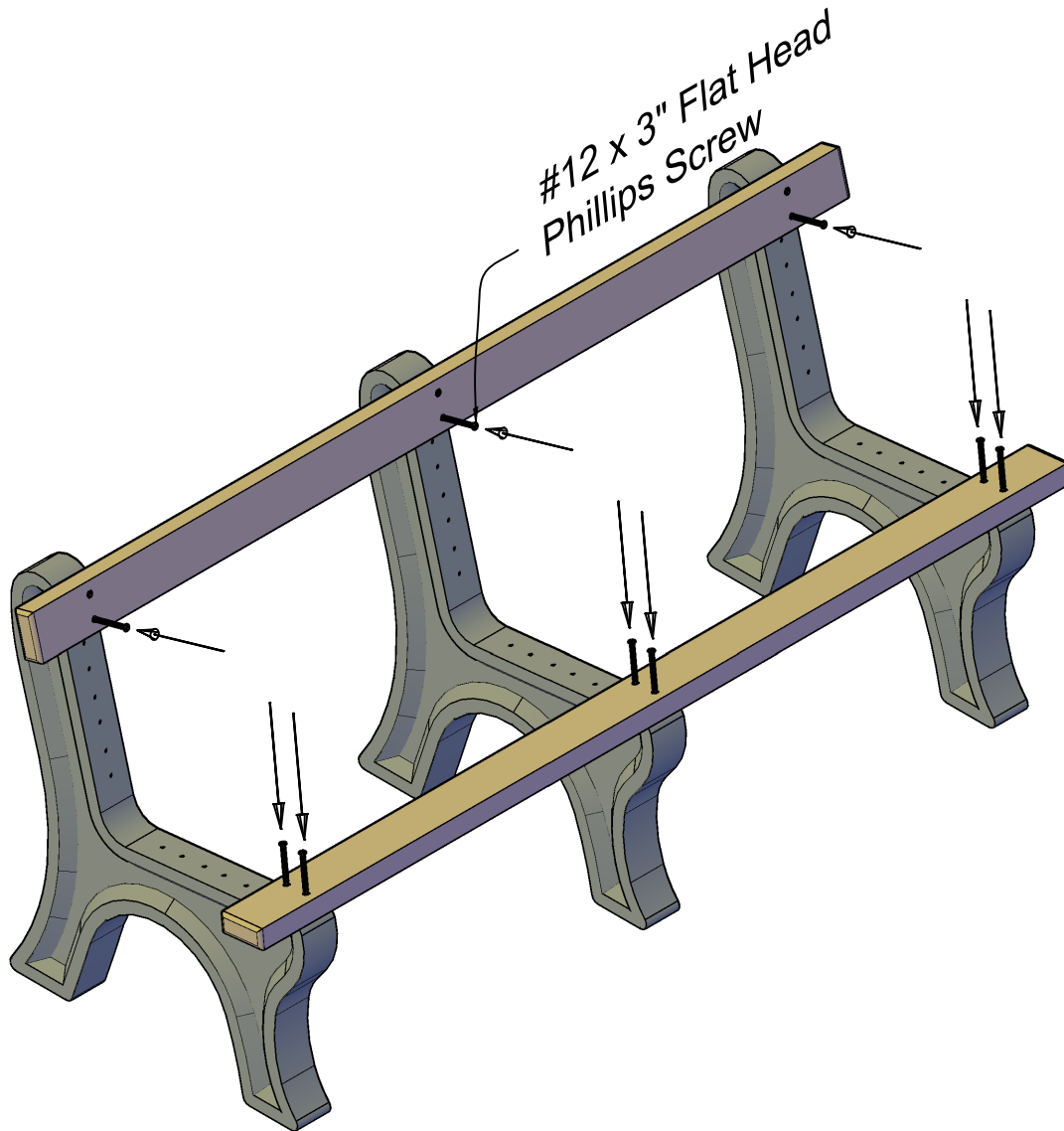

Step #4:

Place a second bench board on position **8**. Repeat Steps 1 - 3 to attach. Use (1) One #12 x 3" Flat Head Phillips Screw per hole to fasten.

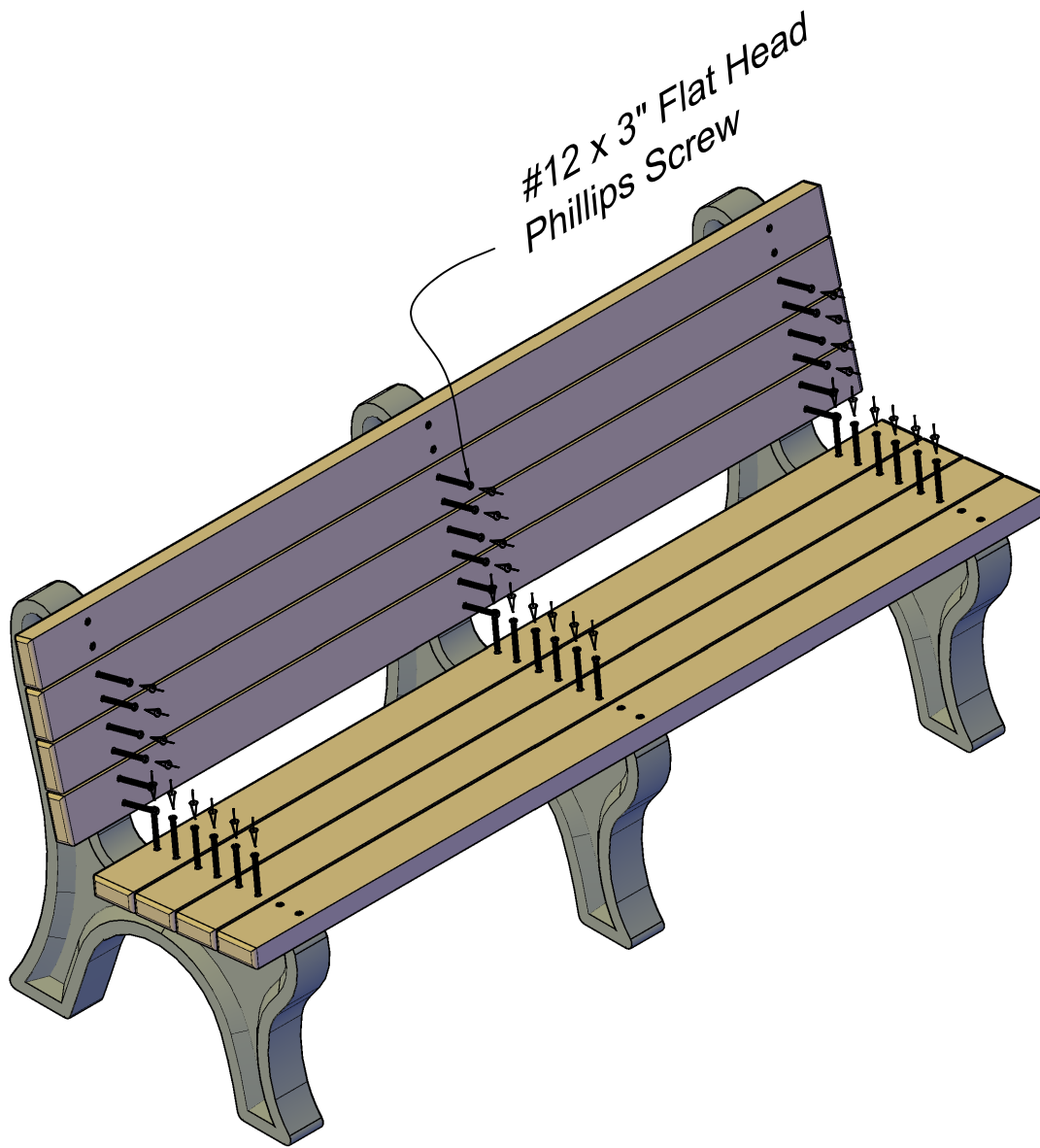

Step #5:

Repeat Steps 1 - 3 to attach bench boards on positions **2, 3, 4, 5, 6 & 7**. Use (1) One #12 x 3" Flat Head Phillips Screw per hole to fasten.

DEAR VALUED CUSTOMER,

THANK YOU FOR PURCHASING THIS PRODUCT. THIS PRODUCT IS MANUFACTURED USING RECYCLED MATERIALS AND MAY HAVE SLIGHT COLOR VARIATIONS, OCCASIONAL SPECKS OF COLOR OR IRREGULAR SURFACE PATTERNS. THESE ARE NORMAL CONDITIONS OF RECYCLED PLASTICS AND MAKE EACH PIECE OF FURNITURE UNIQUE. THESE CHARACTERISTICS DO NOT AFFECT THE STRENGTH, QUALITY OR PERFORMANCE OF THE PRODUCT.

THANK YOU AGAIN FOR PURCHASING THIS PRODUCT AND HELPING OUR ENVIRONMENT.