

# 8 Foot Cambridge Flat Park Bench

For Fastener Pack  
(FP-CB8F-CU-01)

WARNING: FOLLOW ASSEMBLY  
INSTRUCTIONS CLOSELY.  
DAMAGES DUE TO IMPROPER  
ASSEMBLY WILL NOT BE  
COVERED UNDER WARRANTY

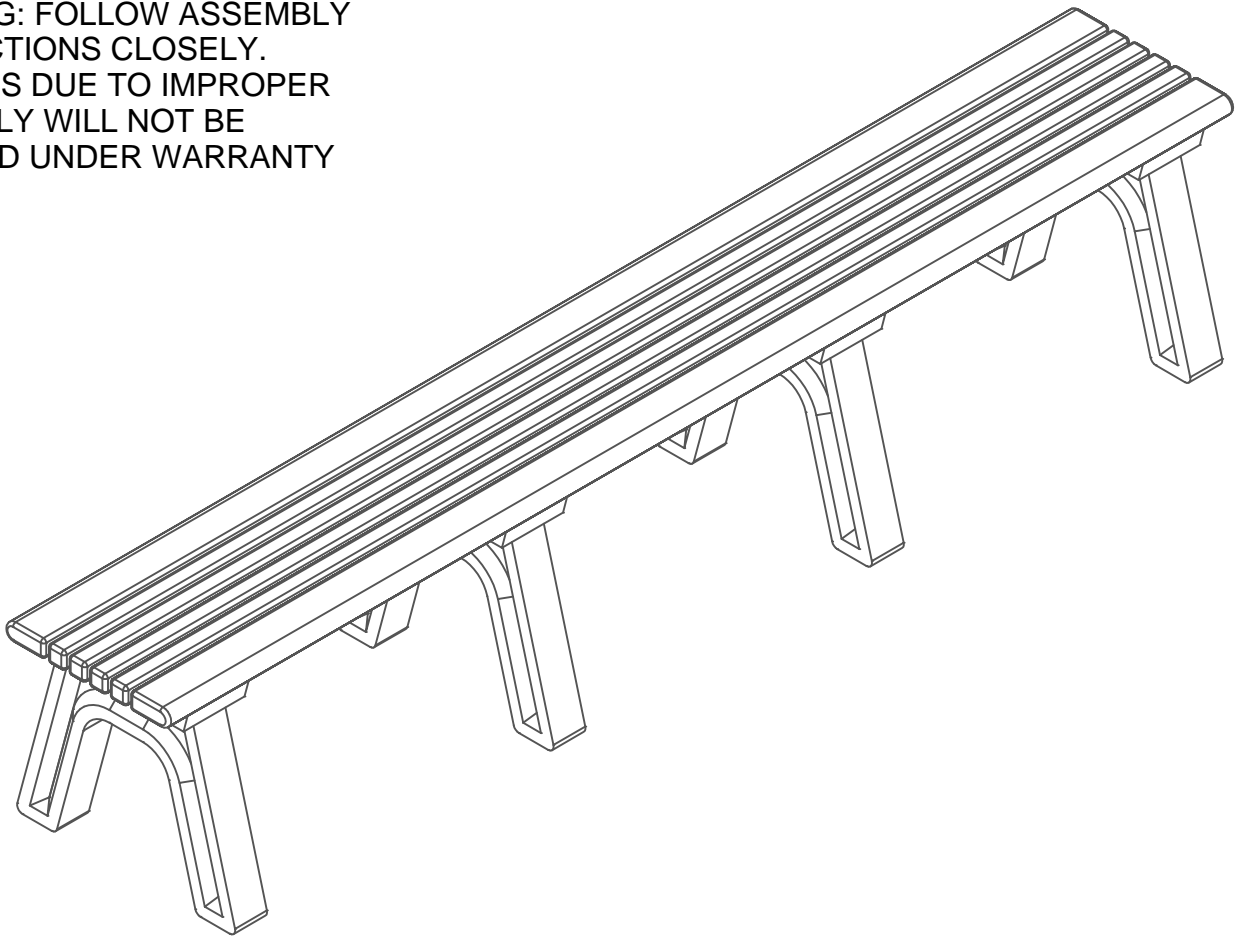

Congratulations !!

You have just purchased the finest recycled plastic  
park bench available. Enjoy !!!

Before assembly, please make sure all components are included.



( 1 ) - One Fastener Pack  
FP-CB8F-CU-01

FP - Fastener Pack

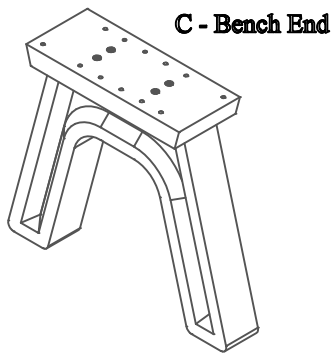

C - Bench End

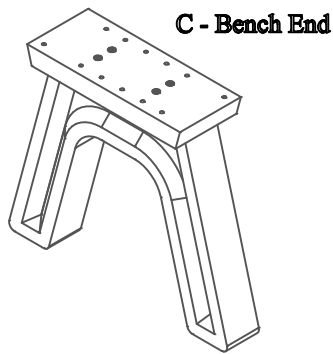

C - Bench End

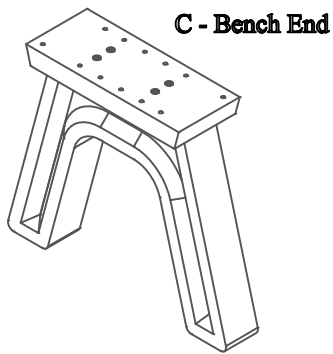

C - Bench End

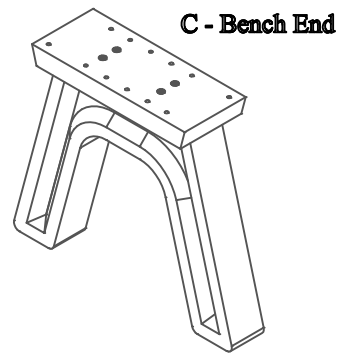

C - Bench End

( 4 ) - Four Bench Ends  
BSA-FME-C-01

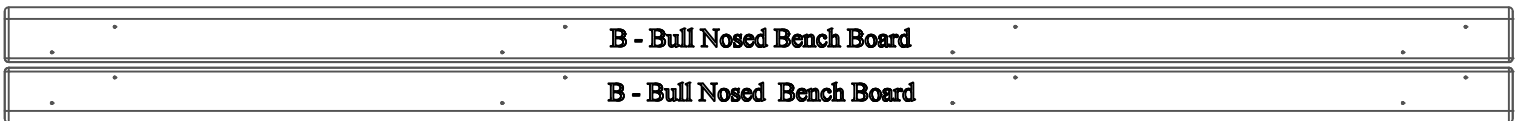

B - Bull Nosed Bench Board

B - Bull Nosed Bench Board

( 2 ) - Two Bull Nosed Bench Boards  
BP-CB8F-B-01



A - Center Bench Board

A - Center Bench Board

A - Center Bench Board

A - Center Bench Board

( 4 ) - Four Center Bench Boards  
BP-CB8F-A-01

Before assembly, please make sure all fasteners are included.

48 - #12 x 2 1/2" Flat Head Phillips Screw



Also needed for this assembly will be the following materials:

1 - #3 Phillips Drive Bit

\*IMPORTANT NOTICE\*:

- DO NOT OVER-TIGHTEN SCREWS.
- USE A DRILL WITH ADJUSTABLE TORQUE FOR BEST RESULTS.
- OVER-TIGHTENING WILL RESULT IN STRIPPING OUT THE PILOT HOLE, AND SCREW WILL "SINK" INTO THE PLASTIC WHICH MAY CAUSE A STRESS FRACTURE.

### Step #1:

Place the Center Bench Boards on a level surface with the pilot holes facing up. On each side of the Center Bench Boards place (1) One Side Bench Board with the pilot holes closest to the Center Bench Boards and facing up.

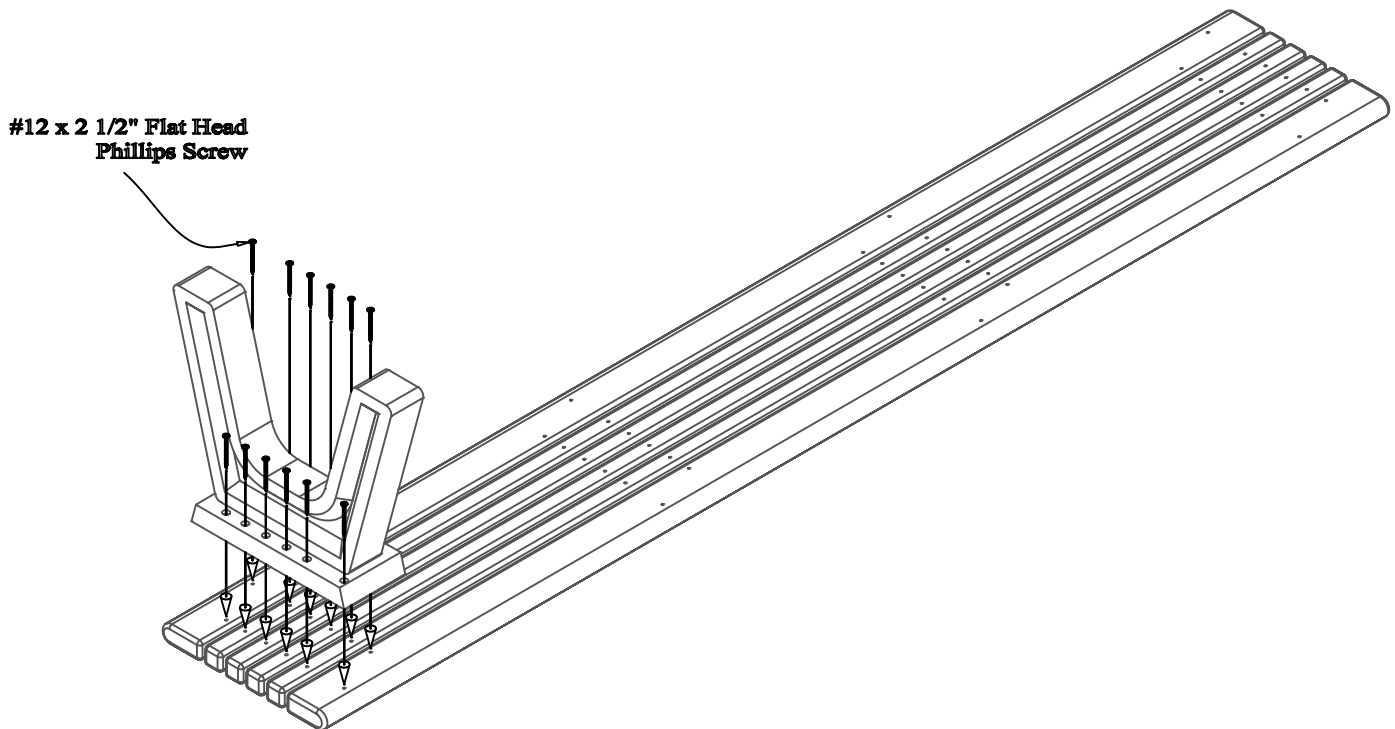

### Step #2:

Place (1) One Bench End in position as shown above being sure to align the pre-drilled holes to the pilot holes in the bench boards. After the holes are properly aligned, fasten with (1) One #12 x 2 1/2" Flat Head Phillips Screw per hole to secure.

Note: Do not tighten screws completely. This will be done in a later step.

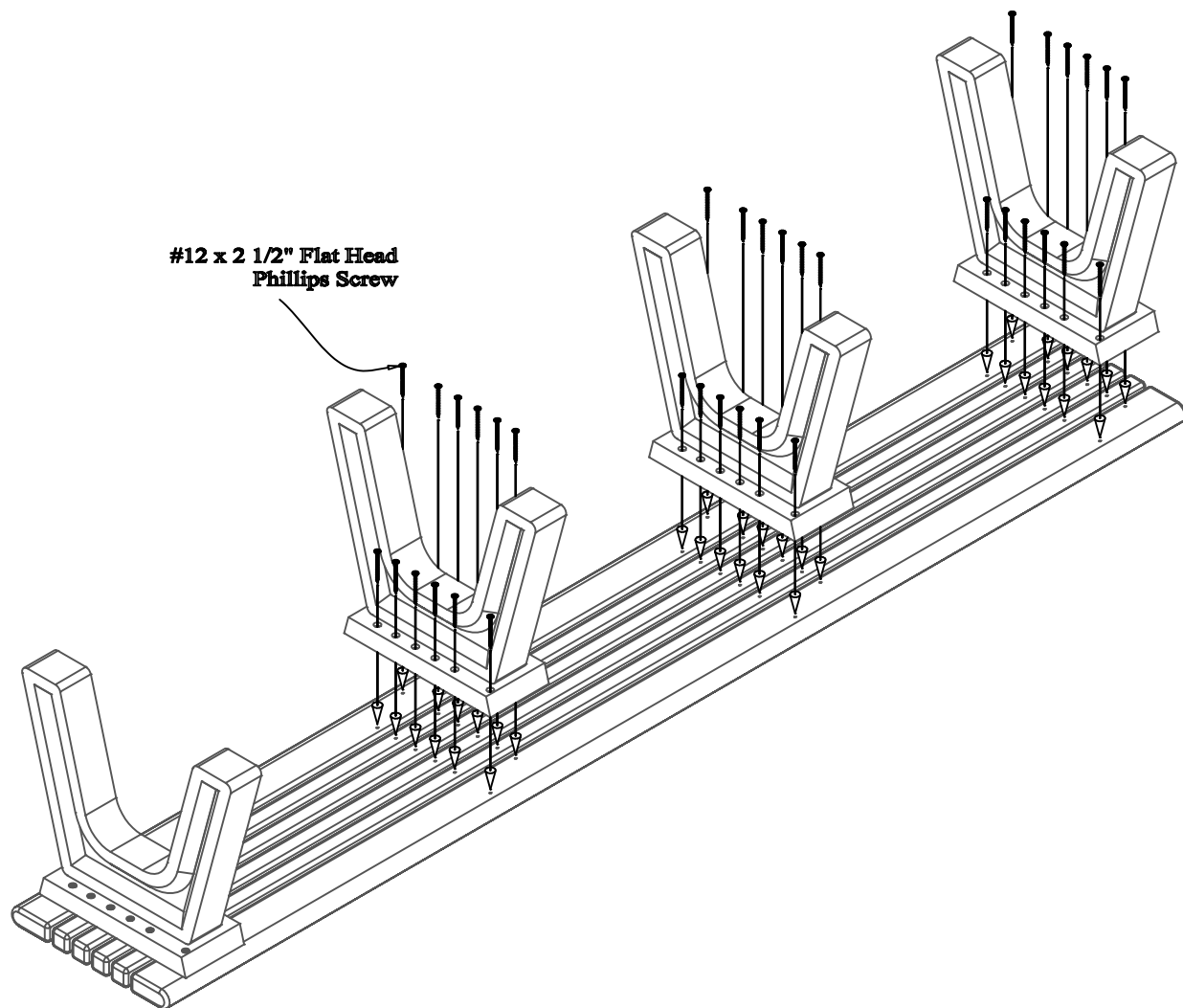

#12 x 2 1/2" Flat Head  
Phillips Screw

### Step #3:

Place the remaining Bench Ends in position as shown above being sure to align the pre-drilled holes to the pilot holes in the bench boards. After the holes are properly aligned, fasten with (1) One #12 x 2 1/2" Flat Head Phillips Screw per hole to secure.

Note: Be sure to tighten all screws completely after this step.

DEAR VALUED CUSTOMER,

THANK YOU FOR PURCHASING THIS PRODUCT. THIS PRODUCT IS MANUFACTURED USING RECYCLED MATERIALS AND MAY HAVE SLIGHT COLOR VARIATIONS, OCCASIONAL SPECKS OF COLOR OR IRREGULAR SURFACE PATTERNS. THESE ARE NORMAL CONDITIONS OF RECYCLED PLASTICS AND MAKE EACH PIECE OF FURNITURE UNIQUE. THESE CHARACTERISTICS DO NOT AFFECT THE STRENGTH, QUALITY OR PERFORMANCE OF THE PRODUCT.

THANK YOU AGAIN FOR PURCHASING THIS PRODUCT AND HELPING OUR ENVIRONMENT.