

# Youth Hexagon Picnic Table

For Fastener Pack  
(FP-OHTY-CU-04)

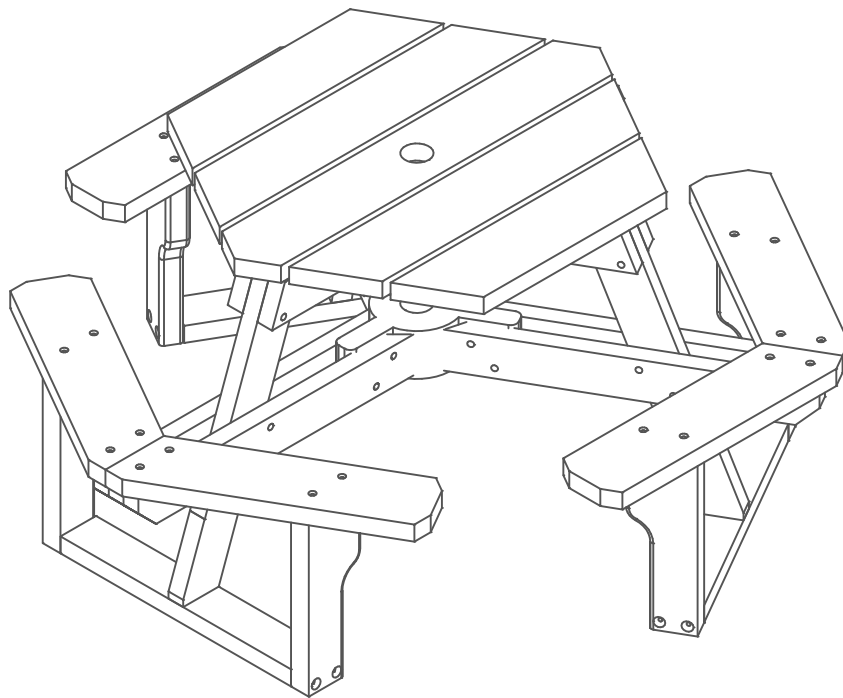

Congratulations !!

You have just purchased the finest recycled plastic  
picnic table available. Enjoy !!!

Before assembly, please make sure all components are included.

**A - Table Top**

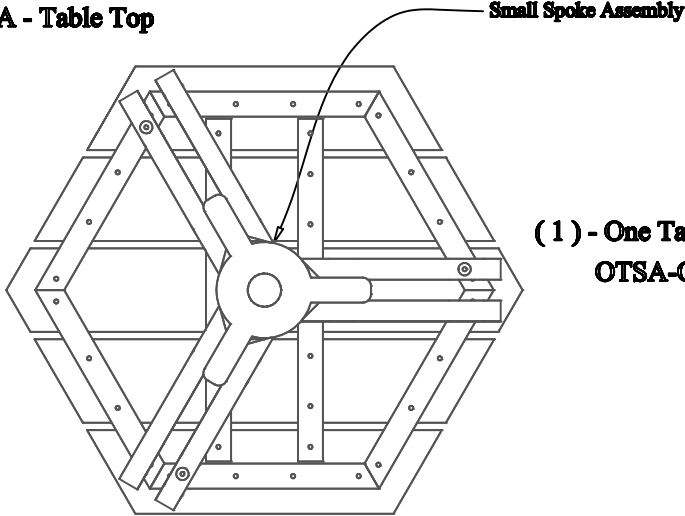

**( 1 ) - One Table Top w/ Small Spoke Assembly  
OTSA-OHTY-A-03**

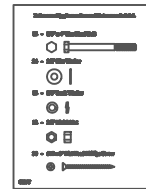

**( 1 ) - One Fastener Pack  
FP-OHTY-CU-04**

**FP - Fastener Pack**

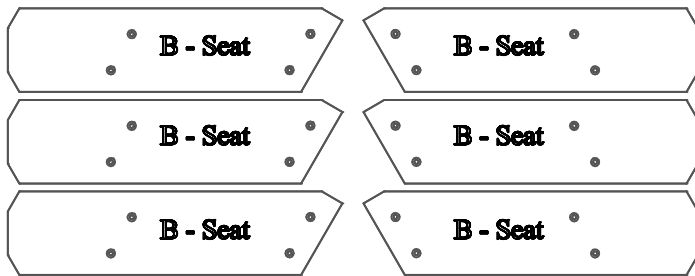

**( 6 ) - Six Seats  
OTP-HY-P-03**

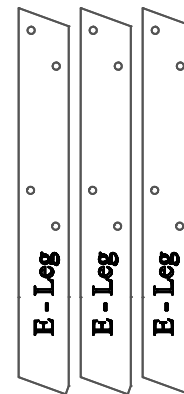

**( 3 ) - Three Legs  
OTP-HY-H-03**

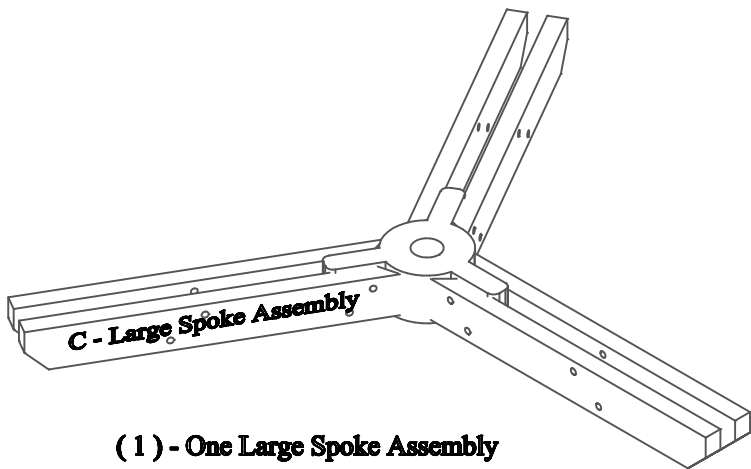

**( 1 ) - One Large Spoke Assembly  
OTSA-HY-D-02**

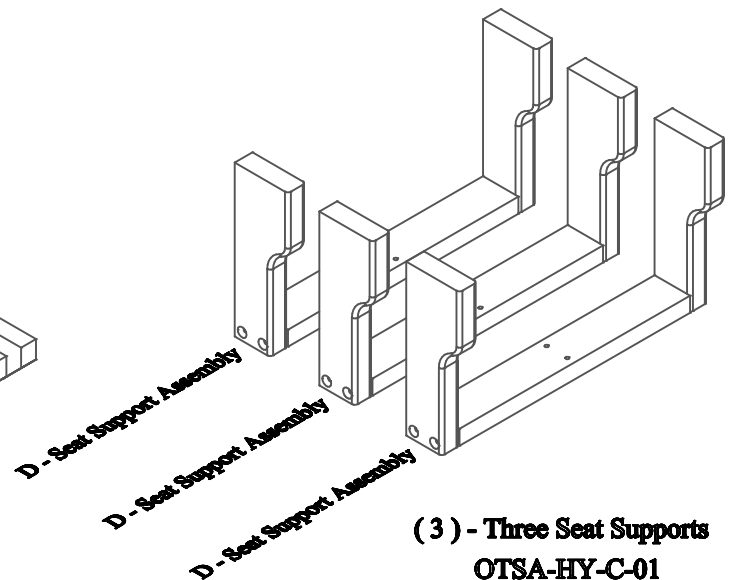

**( 3 ) - Three Seat Supports  
OTSA-HY-C-01**

Before assembly, please make sure all fasteners are included.

12 - 3/8" x 4-1/2" Hex Head Bolt

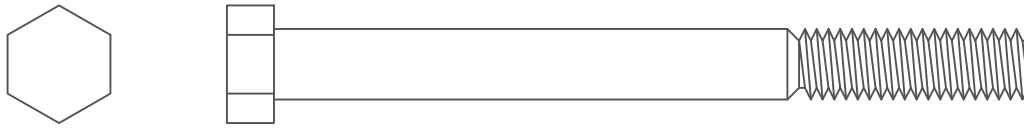

24 - 3/8" Flat Washer

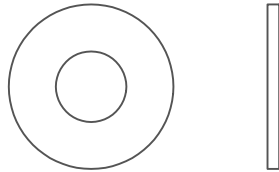

12 - 3/8" Nylon Lock Nut

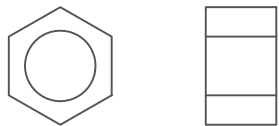

30 - #12 x 2-1/2" Flat Head Phillips Screw

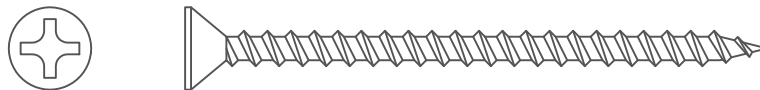

Also needed for this assembly will be the following materials:

1 - #3 Phillips Drive Bit

2 - 9/16" Socket Wrench

**\*IMPORTANT NOTICE\*:**

- \* DO NOT OVER-TIGHTEN SCREWS.
- \* USE A DRILL WITH ADJUSTABLE TORQUE FOR BEST RESULTS.
- \* OVER-TIGHTENING WILL RESULT IN STRIPPING OUT THE PILOT HOLE, AND SCREW WILL "SINK" INTO THE PLASTIC WHICH MAY CAUSE A STRESS FRACTURE.

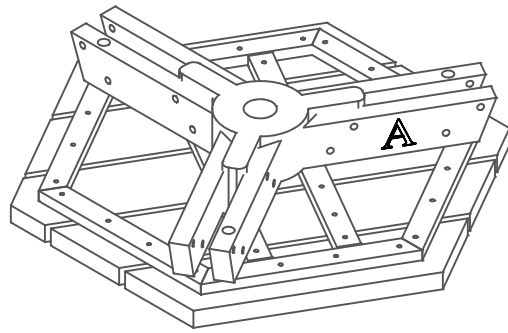

### Step #1:

Place the table top (part A) upside down with the small spoke assembly facing up to begin assembly.

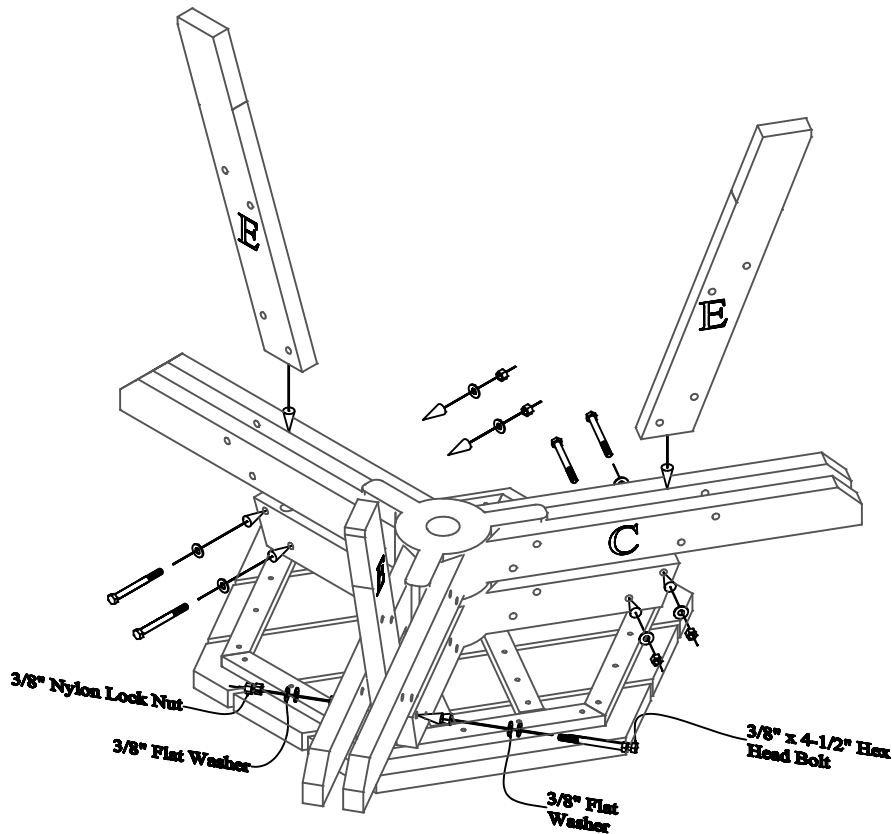

### Step #2:

While the table is upside down, place the large spoke assembly (part C) onto the small spoke assembly as shown above. Slide ( 1 ) One leg (part E) between the propellers of each spoke assembly. Secure the legs to the small spoke assembly. Use ( 1 ) One 3/8" x 4-1/2" Hex Head Bolt and ( 1 ) One 3/8" Flat Washer along with ( 1 ) One 3/8" Flat Washer, and ( 1 ) One 3/8" Nylon Lock Nut per hole to secure.

Do not tighten bolts completely. This will be done in a later step.

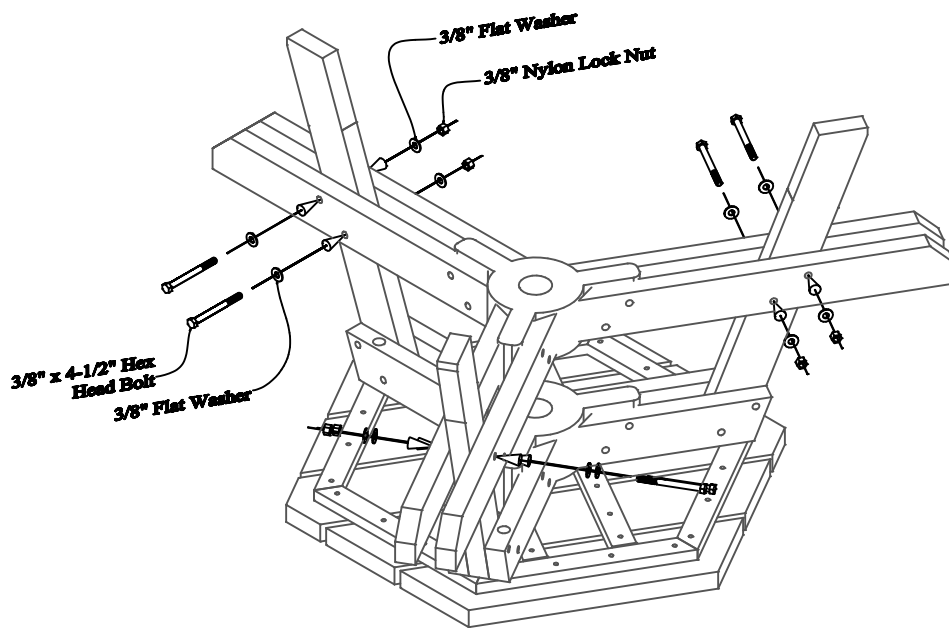

### Step #3:

While the table is still upside down, slide the large spoke assembly up to match the holes to the legs. Secure the large spoke assembly to the legs as shown above. Use ( 1 ) One 3/8" x 4-1/2" Hex Head Bolt and ( 1 ) One 3/8" Flat Washer along with ( 1 ) One 3/8" Flat Washer, and ( 1 ) One 3/8" Nylon Lock Nut per hole to secure.

Be sure to tighten all loose bolts after completing this step.

#12 x 2-1/2" Flat Head  
Phillips Screw

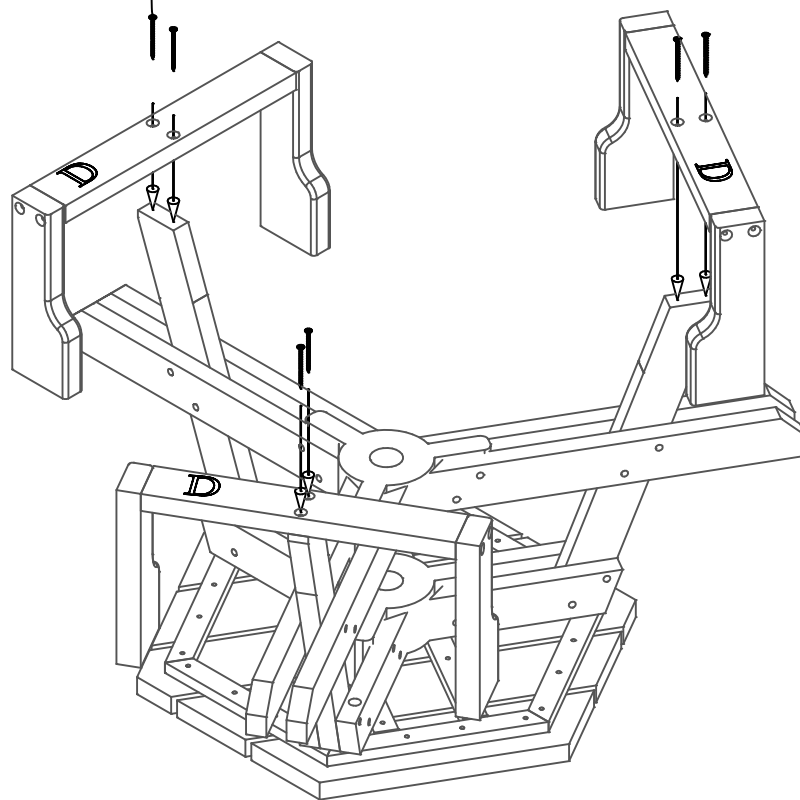

**Step #4:**

While the table is still upside down, fasten the seat support assemblies (part D) to the legs as shown above. Use ( 1 ) One #12 x 2-1/2" Flat Head Phillips Screw per hole to secure.

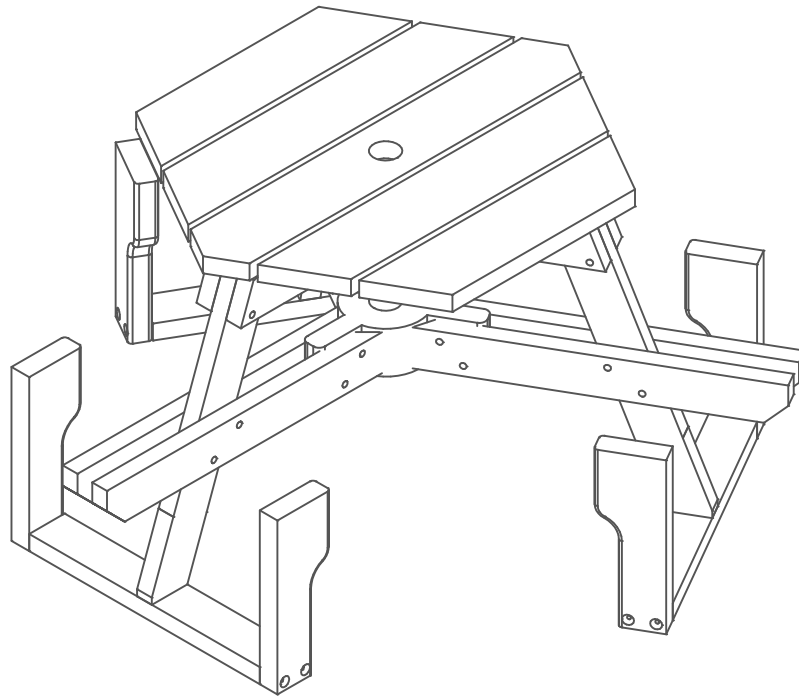

**Step #5:**

Flip the table upright onto it's frame. Please take caution while flipping the table. At this point in assembly the table weighs approximately 82 Pounds.

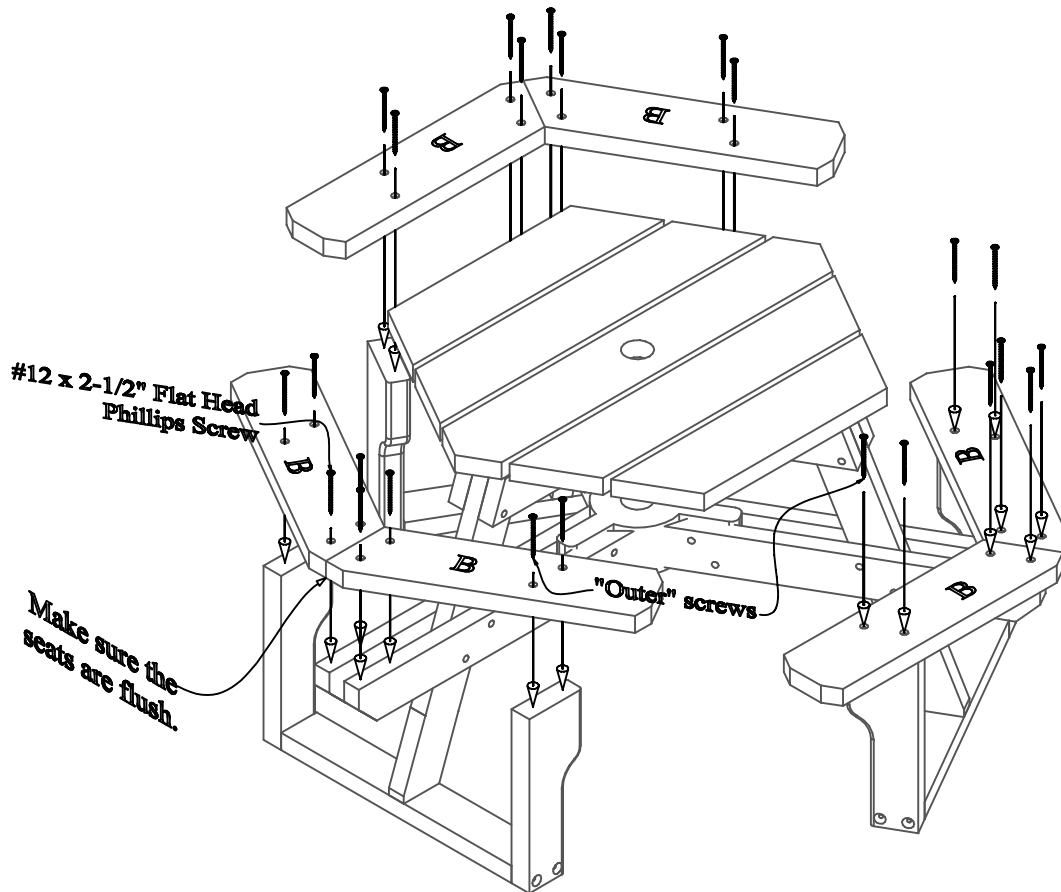

### Step #6:

While the table top is upright, place the seats (part B) into the positions shown above. Line up the pre-drilled holes in the seats with the pilot holes in the large spokes first, making sure that the inner edges of the seats are flush and tight with each other. Attach the "outer" screws going into the seat support assemblies second. Fasten the seats with (1) One #12 x 2-1/2" Flat Head Phillips Screw per hole to secure.



DEAR VALUED CUSTOMER,

THANK YOU FOR PURCHASING THIS PRODUCT. THIS PRODUCT IS MANUFACTURED USING RECYCLED MATERIALS AND MAY HAVE SLIGHT COLOR VARIATIONS, OCCASIONAL SPECKS OF COLOR OR IRREGULAR SURFACE PATTERNS. THESE ARE NORMAL CONDITIONS OF RECYCLED PLASTICS AND MAKE EACH PIECE OF FURNITURE UNIQUE. THESE CHARACTERISTICS DO NOT AFFECT THE STRENGTH, QUALITY OR PERFORMANCE OF THE PRODUCT.

THANK YOU AGAIN FOR PURCHASING THIS PRODUCT AND HELPING OUR ENVIRONMENT.